

NO.	NAME	MATERIAL
1	HOUSING	PBT / Nylon
2	PIN TERM.	PHOS. BRONZE
3	SHELL	BRASS

# SUA-110H\*\*\*

Series \_\_\_\_\_  
 Type \_\_\_\_\_  
 Color \_\_\_\_\_  
 B : Black  
 W : White

Shell \_\_\_\_\_  
 N : Nickel Plated  
 T : Tin Plated  
 F : SPCC

Version \_\_\_\_\_  
 1 : 1.1(1~3u")  
 2 : 2.0(30u"±5%)

Material \_\_\_\_\_  
 B : PBT  
 P : Nylon

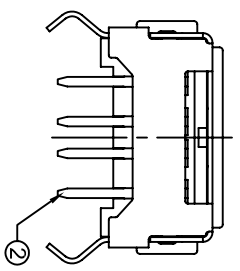
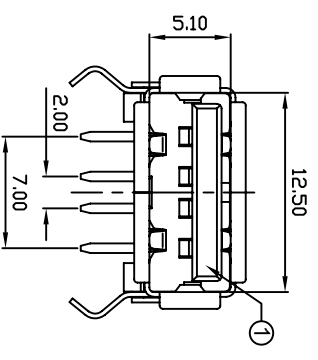
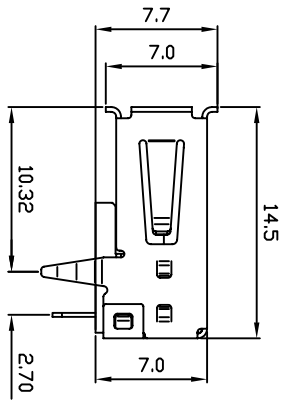
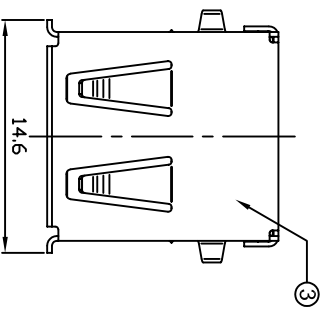

REV	ZONE	REVISION	DATE	APPD.

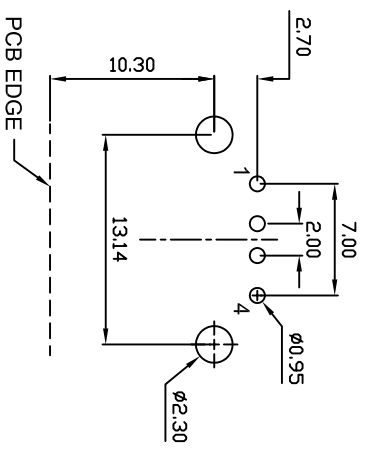

**SUGGESTED PCB LAYOUT**  
 TOP VIEW

APPROVED BY  
**KINSMOOD ELECTRONICS CORP.**

MODEL **SUA-110H\*\*\*** PAGE 1 OF 1

COMPUTER NO. \_\_\_\_\_ UNIT \_\_\_\_\_ SCALE \_\_\_\_\_ PART NAME \_\_\_\_\_

APPD. **Aaron** CKD. **Michael** DWG. **Valiant** DATE **2007-03-12** TOLERANCE **0.000mm ± 0.075mm**  
**0.00 mm ± 0.15 mm**  
**0.0 mm ± 0.25 mm**

USB, TYPE A  
 FLAT 90° DTP

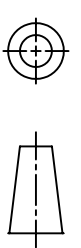

REV. **A.0**